

CITY OF TUCSON

RESIDENTIAL GAS PIPE INSTALLATION STANDARDS

2006 IRC

These standards are intended to be a guide to the homeowner. It is the permit holder's responsibility to provide an installation that complies with the 2006 International Residential Code, and addendums. Contact ICC (www.iccsafe.org) to order publications. All situations are not covered in this "guide". If you are not able to provide a system that complies with the minimum code requirements, hire a licensed professional. Multiple denied inspections may result in re-inspection fees.

A "gas system" includes all gas piping, appliances and equipment. The inspector will need access to all equipment including, but not limited to, the water heater and furnace. The inspector will check existing appliances for any safety defects. Inspectors do not have ladders or tools, and will expect you to provide safe access to all areas. Inspectors will not enter an occupied structure without an adult escort. Any necessary ladders, keys, etc. for access to the system shall be ready at the time of inspection.

Water heaters (WH) and furnaces require a permit when they are replaced or relocated. Water heaters and furnaces that have been replaced must comply with current codes. An appliance is only considered "existing" if it was permitted and approved at the time of installation. Gas WH's that have been replaced with an electric WH also require an electrical wiring permit and inspection. No part of any system may be concealed prior to approval from the inspector.

All materials used in a piping system, including pipe supports, shall be "approved" or "listed" (designed and tested for a specific use). Listed materials shall be installed in accordance with the manufacturer's installation instructions.

Water heaters shall be provided with a temperature and pressure relief valve (T&P) with a relief drain to the outside of the building or to an approved location per code. In the event that there is no way to comply with this requirement due to existing conditions, a "Petition of Appeal to the Building Official" must be completed and submitted. The T&P valve shall be tested at the time of inspection and replaced if leaking.

The permit holder shall provide a 10 psi air test on the entire system using a 15 psi gage (exception: a mobile home interior may be tested with 3 psi). **The entire gas system shall be under test prior to the inspector's arrival.**

Note: If you are replacing or adding gas piping, a plan is required. It is important to verify that the pipe, being replaced or added to, is the correct size for the current code. Existing gas piping may not be properly sized for the currently adopted code. In order to perform a complete review, the following items must be specified:

- The total developed length of the pipe measured from the meter to the furthest appliance served.
- The total BTUH input for each of the gas-fired appliances that are being fed from the gas meter.

**TABLE G2413.4(1) [402.4(2)]
SCHEDULE 40 METALLIC PIPE**

Gas	Natural					
Inlet Pressure	Less than 2 psi					
Pressure Drop	0.5 in. w.c.					
Specific Gravity	0.6					
	PIPE SIZE (inch)					
Nominal	½	¾	1	1¼	1½	2
Actual ID	0.622	0.824	1.049	1.38	1.61	2.067
Length (ft)	Capacity in Cubic Feet of Gas per Hour					
10	172	360	678	1,390	2,090	4,020
20	118	247	466	957	1,430	2,760
30	95	199	374	768	1,150	2,220
40	81	170	320	657	985	1,900
50	72	151	284	583	873	1,680
60	65	137	257	528	791	1,520
70	60	126	237	486	728	1,400
80	56	117	220	452	677	1,300
90	52	110	207	424	635	1,220
100	50	104	195	400	600	1,160
125	44	92	173	355	532	1,020
150	40	83	157	322	482	928
175	37	77	144	296	443	854
200	34	71	134	275	412	794
250	30	63	119	244	366	704
300	27	57	108	221	331	638

G2424.1 (415.1) Interval of support.

Piping shall be supported at intervals not exceeding the spacing specified in Table G2424.1. Spacing of supports for CSST shall be in accordance with the CSST manufacturer's instructions.

STEEL PIPE, NOMINAL SIZE OF PIPE (inches)	SPACING OF SUPPORTS (feet)	NOMINAL SIZE OF TUBING SMOOTH-WALL (inch O.D.)	SPACING OF SUPPORTS (feet)
½	6	½	4
¾ or 1	8	5/8 or ¾	6
1¼ or larger (horizontal)	10	7/8 or 1 (horizontal)	8
1¼ or larger (vertical)	Every floor level	1 or Larger (vertical)	Every floor level

For SI: 1 inch = 25.4 mm, 1 foot = 304.8 mm.

Future connections or undesignated “tee” outlets are not allowed unless specifically shown on your approved plan; the system must be sized to handle any future demand.

An accessible shut-off valve shall be installed in the fuel supply piping within 6 feet of the appliance and ahead of the union connection to the appliance. Approved, and correctly sized flex connectors, shall be on site. When the gas meter is in a remote location (i.e. in an alley), install an emergency gas shut-off valve (SOV) at the building.

All exposed gas piping shall be kept at least 6 inches above grade and 1½” above structure. Pipe supports used outside of the building shall be weather resistant.

Piping installed below grade shall be “listed” for below grade installations (factory coated) and any uncoated fittings and tool marks shall be protected with the use of pipe wrap primer and PVC pipe wrap. Pipe wrap shall be installed neatly without wrinkles. Non-metallic piping requires a minimum #18 gage yellow tracer wire secured at 8 feet on center. All gas piping for mobile homes and all plastic gas piping requires 18 inches of cover from the top of the pipe to ground level. DO NOT cover the piping until it has been inspected. Provide clean fill material on site at the time of inspection for backfilling purposes. Remove all rocks from the trench and “shade the pipe” with clean sand or dirt. All below grade piping shall be continuously supported. Metallic piping may be installed with only 12 inches of cover if it is not in an area where damage may occur. Below grade offsets may not be made in a public right of way.

Things to remember:

- Unions and bushings may not be concealed.
- Sediment traps are required at the water heater and furnace inlets.
- All roof penetrations shall have an approved (listed) flashing.
- All flashing shall be sealed and installed per listing.
- Type B or other currently approved venting materials are required.
- Exhaust vent piping shall be secured with galvanized sheet metal screws.
- Proper vent terminations and clearances from combustibles are required.
- Combustion air openings are required for gas-fired equipment.
- Gas piping shall be electrically bonded.

Refer to your code book and installation instructions for further information. This “guide” addresses some of the commonly noted requirements. There are too many code sections that apply to list all of them here and not all code sections will apply to each situation. The inspector will inform you of any additional requirements that apply to your situation.

G2413.2 (402.2) Maximum gas demand.

The volume of gas to be provided, in cubic feet per hour, shall be determined directly from the manufacturer's input ratings of the appliances served. Where an input rating is not indicated, the gas supplier, appliance manufacturer or a qualified agency shall be contacted, or the rating from Table G2413.2 shall be used for estimating the volume of gas to be supplied.

The total connected hourly load shall be used as the basis for pipe sizing, assuming that all appliances could be operating at full capacity simultaneously. Where a diversity of load can be established, pipe sizing shall be permitted to be based on such loads.

TABLE G2413.2 (402.2)

APPROXIMATE GAS INPUT FOR TYPICAL APPLIANCES

TABLE G2413.2 (402.2)

APPROXIMATE GAS INPUT FOR TYPICAL APPLIANCES

APPLIANCE (Approx.)	INPUT BTU/H
Space Heating Units	
Hydronic boiler	
Single family	100,000
Multifamily, per unit	60,000
Warm-air furnace	
Single family	100,000
Multifamily, per unit	60,000
Space and Water Heating Units	
Hydronic boiler	
Single family	120,000
Multifamily, per unit	75,000
Water Heating Appliances	
Water heater, automatic instantaneous	
Capacity at 2 gal./minute	142,800
Capacity at 4 gal./minute	285,000
Capacity at 6 gal./minute	428,400
Water heater, automatic storage, 30- to 40-gal. tank	35,000
Water heater, automatic storage, 50-gal. tank	50,000
Water heater, domestic, circulating or side-arm	35,000
Cooking Appliances	
Built-in oven or broiler unit, domestic	25,000
Built-in top unit, domestic	40,000
Range, free-standing, domestic	65,000
Other Appliances	
Barbecue	40,000
Clothes dryer, Type 1 (domestic)	35,000
Gas fireplace, direct vent	40,000
Gas light	2,500
Gas log	80,000
Refrigerator	3,000

For SI: 1 British thermal unit per hour = 0.293 W, 1 gallon = 3.785 L,
1 gallon per minute = 3.785 L/m.

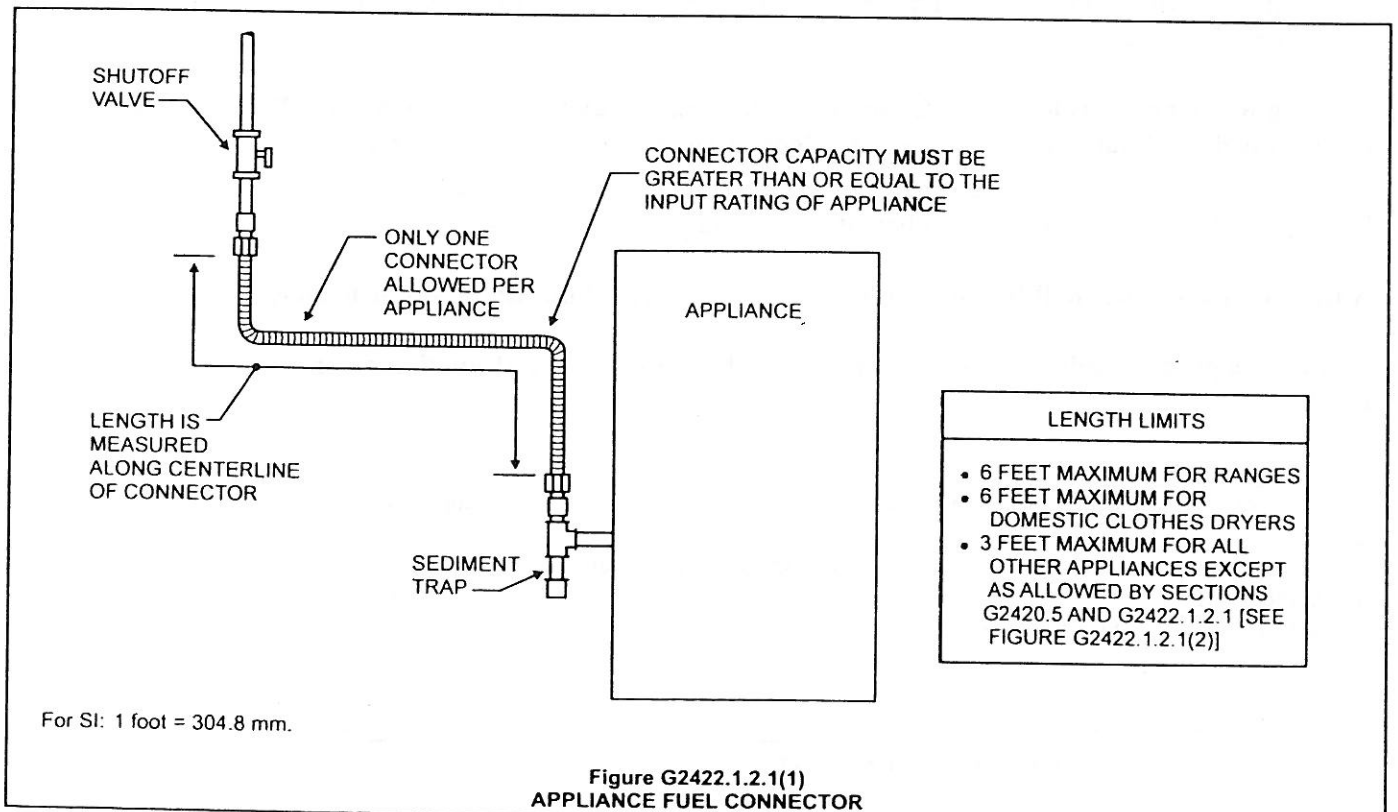
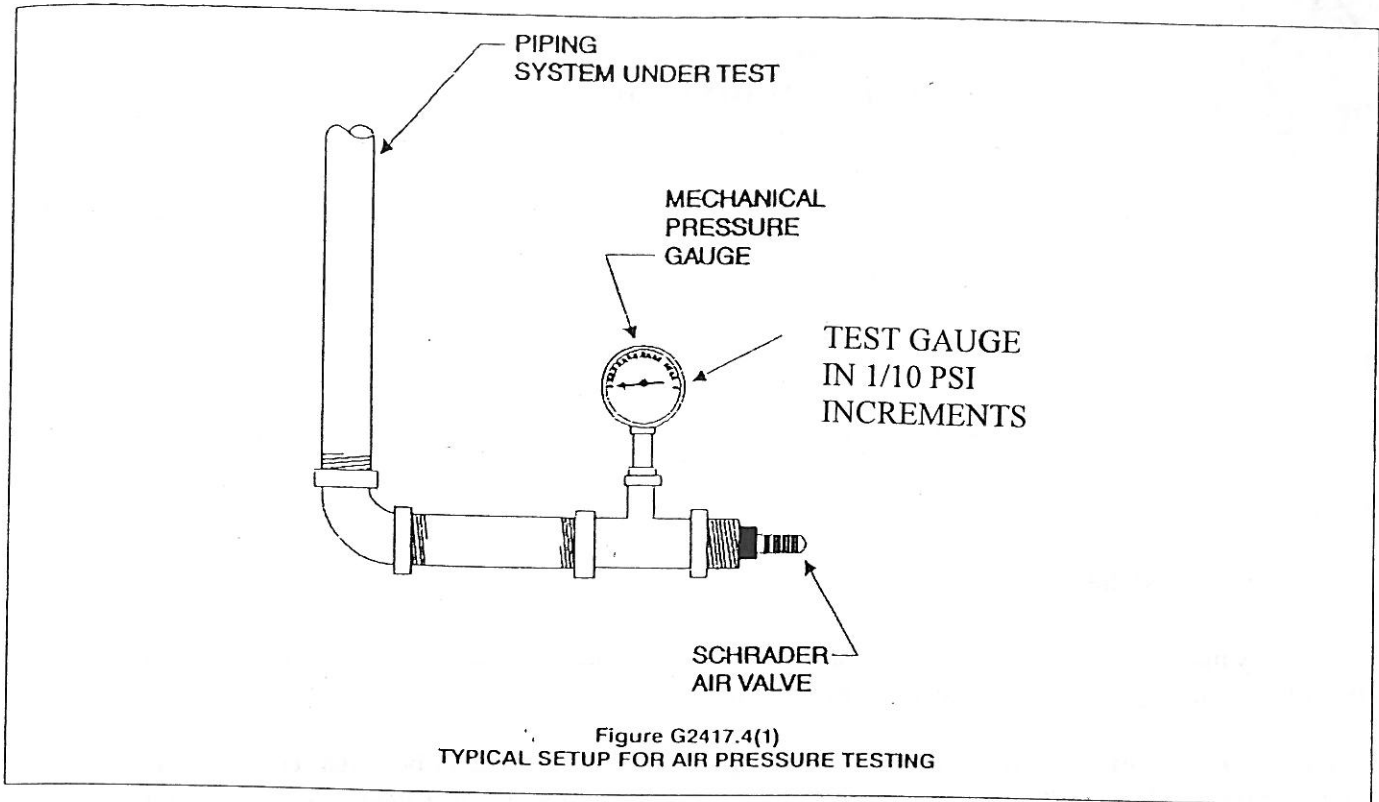



PLANNING & DEVELOPMENT SERVICES DEPARTMENT
 201 N STONE AV
 PO BOX 27210, TUCSON AZ 85726-7210
 (520) 791-5550

ACTIVITY #

**PETITION OF APPEAL
 TO THE BUILDING OFFICIAL**

** This is a legal document that **MUST** be detailed, accurate and complete. Supporting data may be attached and submitted if needed. **

PROJECT NAME	PROJECT ADDRESS	DATE
OWNER'S NAME	OWNER'S ADDRESS	PHONE
TENANT'S NAME	TENANT'S ADDRESS	PHONE
APPELLANT'S NAME	APPELLANT'S ADDRESS	PHONE

APPELLANT'S RELATIONSHIP TO PROJECT

Appeal is hereby made to the Building Official for an alternate method/material, or interpretation of, Section 608.5 and 508.5 of the Uniform Plumbing Code as adopted by the City of Tucson.

Water Heater temperature and pressure relief valve (tprv) discharge line is to be extended at a downward angle to the exterior of the building. Discharge from a relief valve into a water heater pan is prohibited.

Explanation of why conformance with the above requirement on the project presents an unusual problem. (Use attachment if necessary)

Existing water heater is located in an interior closet and away from exterior walls. There is no ready access to the outside without either trenching the floor or relocating the water heater.

State specifically what is proposed in lieu of literal compliance:

A tprv discharge line shall be run to a metal drip pan located under the water heater.

Owner accepts and understands that if the water heater or tprv malfunction extensive water damage could result.

 Owners signature if appellant is other than owner

 Appellant

 Title

DECISION OF THE INSPECTOR

STIPULATIONS

- APPROVED
- APPROVED W/STIPULATIONS
- DENIED

DATE

DIRECTOR'S SIGNATURE